

Double torsion fracture testing of high-density polyethylene

B. J. EGAN, O. DELATYCKI

Department of Industrial Science, University of Melbourne, Parkville, Victoria 3052, Australia

The fracture of polyethylene has been studied extensively using conventional testing geometries such as three-point bending (TPB) and single-edge notch tension (SENT). These geometries are of limited utility for studying crack growth, because the crack speed is constantly changing and the crack front is in the centre of the specimen. Double torsion (DT) is a fracture geometry that suffers neither of these disadvantages, yet has only received limited attention in the literature. Its use has been limited to highly brittle materials such as glass, ceramics, thermosetting plastics and PMMA. In contrast to these materials, high-density polyethylene (HDPE) is an inherently ductile polymer. Before the advantages of DT can be exploited for testing HDPE, it is first necessary to demonstrate the validity of DT fracture measurements performed on such a ductile material. In this paper it is shown that at moderate rates of loading and at temperatures below 0 °C, valid double torsion fracture results can be obtained for an ethylene 1-butene copolymer. A novel technique for specimen preparation and a simple method for accurately monitoring crack growth are also described.

1. Introduction

The fracture of polyethylene has been studied extensively. These studies have been performed using conventional fracture geometries such as three-point bending (TPB) [1–7] and single-edge notch tension (SENT) [3, 8–12]. Although these geometries are widely used, their utility for studying crack growth is limited. In TPB and SENT specimens the crack is longest at the centre of the specimen. This makes it difficult to monitor the crack tip in opaque materials. Further, the crack path is short and the crack growth is continually accelerating. For these reasons there have been few published studies on crack growth in high-density polyethylene.

The double torsion geometry, introduced by Outwater and Gerry [13] in the mid 1960s, is a relatively unexploited fracture configuration that is well suited to the study of crack growth (Fig. 1). In double torsion tests the crack propagates at a constant speed over long distances. Also, the crack tip is located at the surface of the specimen. This is particularly advantageous, because it allows optical or electrical measurement of the propagation of the crack.

The double torsion geometry has mostly been used to study the fracture of glass [14–17], brittle metals [18–21] and ceramics [22–25]. Its application to polymers has been limited to thermosets [26–29] and highly brittle thermoplastics such as PMMA [20, 30–33]. In contrast to these materials, high-density polyethylene (HDPE) is an inherently ductile polymer. The application of double torsion fracture testing to such a ductile material has not been documented in the literature. Before the advantages of double torsion fracture testing can be exploited with HDPE, it is first

necessary to establish whether or not valid fracture results can be obtained. This paper describes the conditions under which valid fracture measurements can be obtained for high-density polyethylene tested

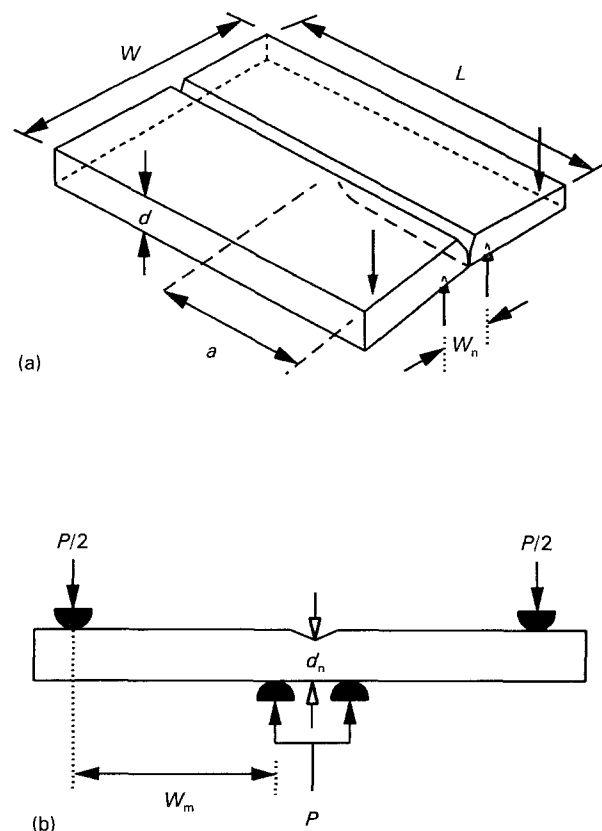

Figure 1 Schematic diagram of the double torsion fracture geometry: (a) perspective view, (b) end view.

in double torsion. A novel technique for specimen preparation and a simple method for accurately monitoring crack growth are also described.

2. Experimental procedure

2.1. Material

A high-density ethylene 1-butene copolymer was used to evaluate the validity of testing polyethylene in double torsion. This grade of polyethylene is used, typically, to manufacture water-distribution pipes. Characterization of the resin showed it to contain 1.3 ethyl branches per 1000 main chain carbons, to have a density of 0.957 g cm^{-3} , and molecular weights of $\bar{M}_w = 130\,000$ and $\bar{M}_n = 10\,300$.

2.2. Specimen preparation

Fracture specimens of HDPE are conventionally prepared from compression-moulded plaques. This is a slow and tedious process. In this work a novel technique was developed for preparation of double torsion fracture specimens. This utilized a $2\frac{1}{2}$ in extruder, and allowed test pieces to be moulded continuously. The experimental arrangement is illustrated schematically in Fig. 2. A specially manufactured die with a circular orifice 40 mm in diameter was fitted to the extruder.

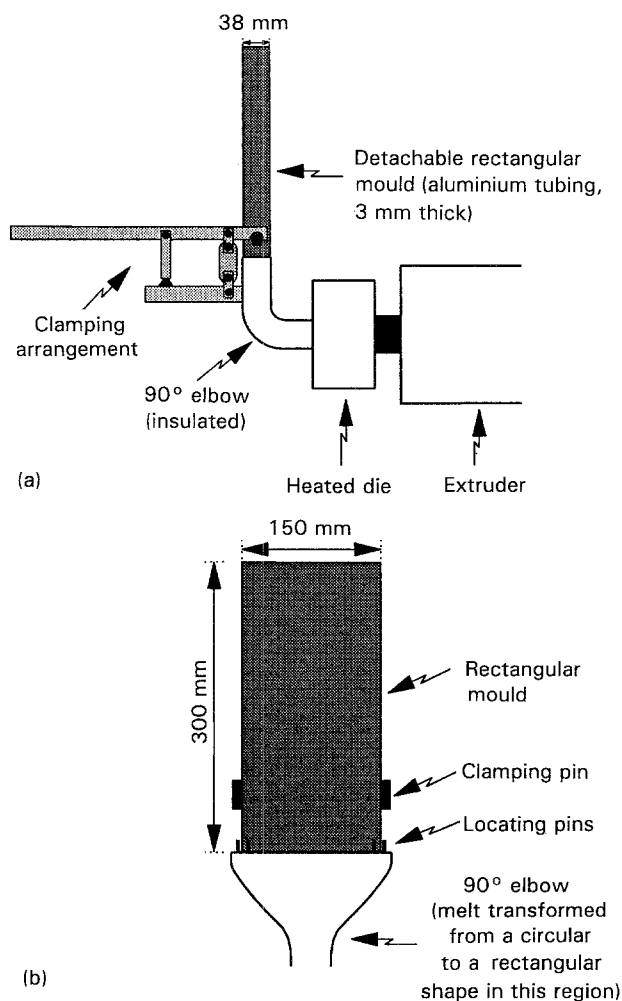

Figure 2 Schematic illustration of the equipment used to mould void-free rectangular billets of HDPE: (a) side view, (b) front view.

Connected to the die was a 90° elbow. This was shaped to transform the melt from a circular to a rectangular section. Lengths of rectangular aluminium tubing were clamped to the end of the elbow. When a section of tubing was filled, the melt was cut and a new length of tube clamped to the elbow. The filled tubes were immediately placed in an oven to be annealed at 110°C for 1 h, after which the oven was switched off and allowed to cool to room temperature. Owing to shrinkage, the rectangular billets were easily removed from the tubing. These billets were entirely free of voids.

Double torsion test pieces were machined from the extruded billets. The width of double torsion specimens should be at least twelve times the thickness, and the length to width ratio should be greater than two [34]. The extruded billets were 130 mm wide. To conform with the recommended ratios, samples measuring 130 mm wide \times 280 mm long \times 11 mm thick were prepared. In double torsion fracture tests it is also necessary to cut a groove along the centre of the specimen to prevent the growing crack from wandering [21, 35–37]. A 1 mm deep 60° chevron notch was machined.

2.3. Specimen isotropy

To minimize orientation in the polyethylene billets, a backing plate and screen pack were not used in the extruder. Wide-angle X-ray analysis was performed to check that the flow process did not produce residual orientation. Anisotropy is indicated by a change in peak intensity as the sample is rotated in the X-ray beam [38, 39].

Wide-angle X-ray diffraction (WAXD) spectra were recorded using a Philips PW1050 diffractometer with monochromatic Co(Fe) radiation. WAXD specimens were machined from an extruded billet both perpendicular and parallel to the direction of flow. The corresponding diffraction patterns are shown in Fig. 3. For the purpose of clarity these spectra have been offset in the vertical axis. The relative peak intensities are identical for both orientations. This shows that the method of manufacture described above is a reliable means of rapidly producing isotropic fracture specimens.

2.4. Fracture mechanics

Double torsion fracture was pioneered using extremely brittle materials, for which the deflection at the point of loading is small. In these circumstances the critical stress intensity factor in double torsion is given by [34]

$$K_{Ic} = PW_m \left[\frac{3}{Wd^3 d_n (1 - \nu) \xi} \right]^{1/2} \quad (1)$$

where ν is the Poisson's ratio of the test material, and ξ is a function of the specimen width and thickness. This equation assumes that the test material behaves in a linear elastic manner. As yet, non-linear fracture mechanics has not been developed for the double torsion geometry.

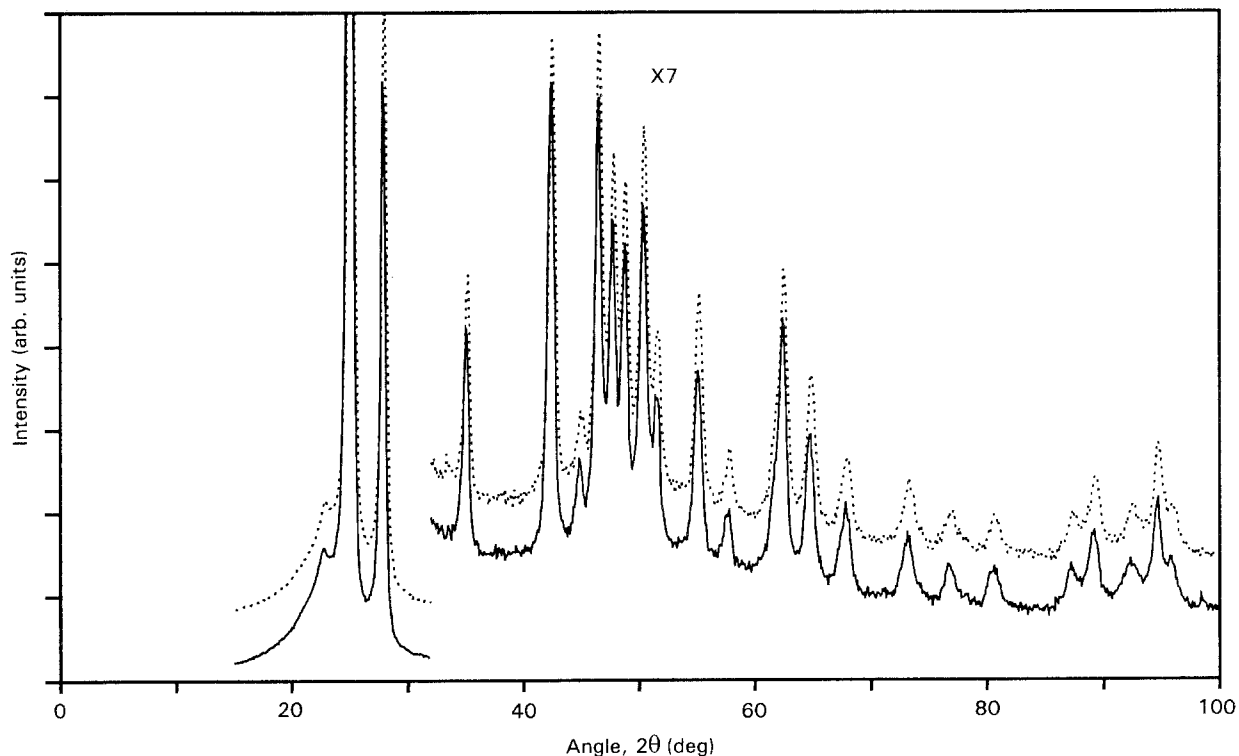

Figure 3 WAXD spectra of moulded section taken (···) perpendicular and (—) parallel to the flow direction. The spectra have been off-set for the purpose of clarity.

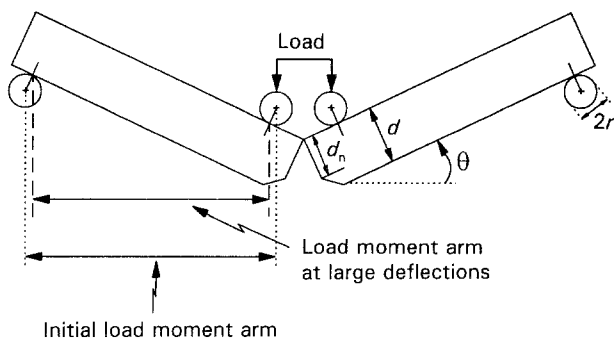

Figure 4 Diagram showing the variation in load moment arm at large deflections.

A significant amount of deformation occurs at the point of loading in tough polymeric materials. When large deflections occur it is necessary to apply a correction to the fracture toughness calculated by Equation 1. Such a correction was developed by Hine *et al.* [35], and further improved by Leever [40]. For double torsion specimens undergoing large deflections, the corrected critical stress intensity factor is given by

$$K_{Ic} = K_{Ic}^* \left\{ \sec^2 \theta \left[1 - \left(\frac{2r + d}{W_m} \right) \sin \theta \right] \right\} \quad (2)$$

where K_{Ic}^* is the stress intensity factor calculated from Equation 1, r is the radius of the loading spheres, and θ is defined as shown in Fig. 4. This correction has been applied to all the results presented in this paper.

2.5. Fracture testing

A double torsion loading rig was built for use in an

Instron model 1026 tensile testing machine. The load was applied through four 10 mm diameter steel ball bearings. These were positioned to give load point spacings of $W_m = 47.5$ mm and $W_n = 15$ mm (refer Fig. 1). The loading fixture also incorporated an arm extending along the centre axis of the specimen. This supported the sample before a load was applied, and also facilitated accurate alignment of the sample. Specimens were fractured with the groove on the tensile surface. A crosshead speed of 5 mm min^{-1} was used for all tests.

Prior to testing, a through cut was inserted a short distance along the apex of the groove. A load was then applied to the specimen at a slow rate of loading until crack propagation commenced. This produced a sharp pre-crack.

The tensile testing machine was fitted with a thermally insulated cabinet. The temperature of the specimen could be controlled using a combination of liquid nitrogen for cooling, and electric coils for heating.

3. Results and discussion

3.1. Crack initiation

A typical load-time graph for HDPE tested at 0°C and a crosshead speed of 5 mm min^{-1} is shown in Fig. 5. Because double torsion is a constant K_I geometry, the load remains constant for a significant time. Crack extension was observed prior to the load reaching a plateau. To calculate the fracture toughness it is necessary to know the load at crack initiation. This can be determined by monitoring when the crack front begins to extend.

The most convenient means of monitoring crack growth is to measure the resistance of a series of

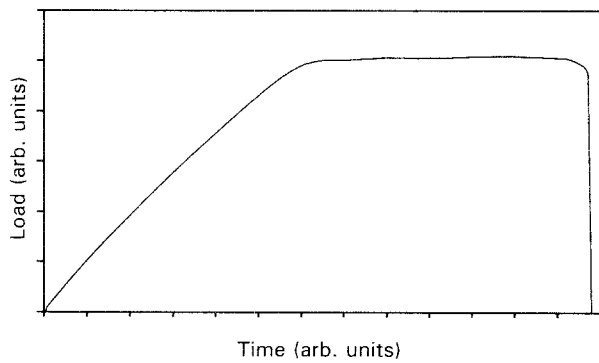

Figure 5 A typical load versus deflection trace recorded at 0°C using a crosshead speed of 5 mm min⁻¹.

conductive lines placed across the crack path [35, 41, 42]. These are successively torn apart as the crack propagates. An increase in resistance of the total grid occurs every time a ligament is broken. The edge of each line defines an exact geometric location, and so each step in the resistance-time curve can be related to a precise length of the crack.

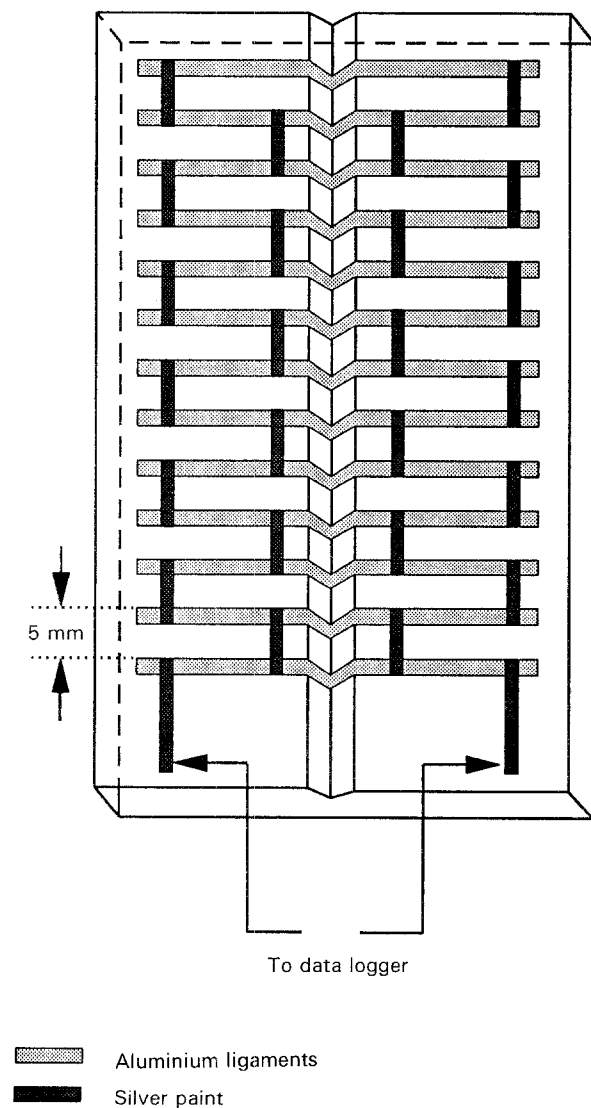

Figure 6 Schematic diagram of the grid pattern used to monitor crack growth in HDPE double torsion specimens.

Aluminium ligaments were vapour deposited on to the surface of the HDPE fracture samples. Sharp ligament edges were formed by the use of a mask which penetrated to the base of the groove. The individual ligaments were spaced 5 mm apart and were joined in parallel using a resistive silver paint. The novel connection pattern shown in Fig. 6 was used so that the ligament about to be broken formed the path of lowest electrical resistance. This ensures a detectable jump in the resistance-time trace.

A Datataker DT100L data logger was used to record simultaneously resistance and load as a function

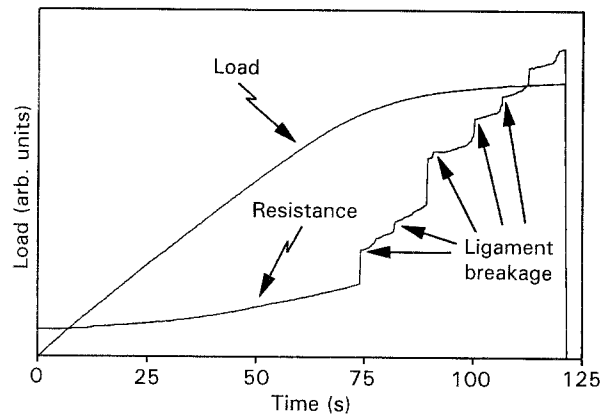

Figure 7 Typical load-time and resistance-time data recorded for HDPE tested in double torsion at 0°C using a crosshead speed of 5 mm min⁻¹.

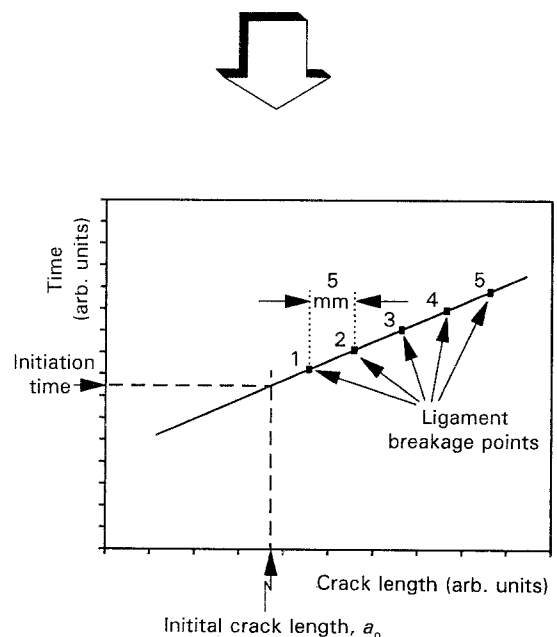
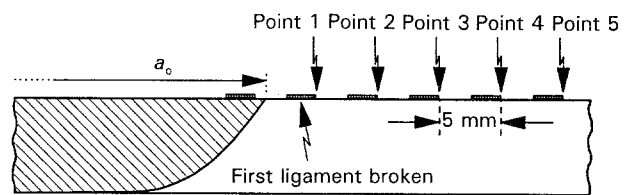

Figure 8 Illustration of the procedure used to calculate the crack initiation time.

of time. Typical results for a sample tested at 0°C and 5 mm min⁻¹ are presented in Fig. 7. The first point on a graph of crack length versus time is established by measuring the distance from the end of specimen to the first grid line broken. Each subsequent jump in resistance corresponds to a 5 mm increment in crack growth. Extrapolation of the data for crack length versus time to the initial crack length, a_0 , allows the initiation load to be determined (Fig. 8). This load is used to calculate the fracture toughness, K_{Ic} . For the HDPE tested, a constant speed was not attained until after the crack had grown a short distance. To minimize the error that this crack acceleration introduced into the extrapolation procedure, only the first two jumps in resistance were used to determine the time and load at crack initiation.

3.2. Testing the validity of the results

3.2.1. Constant stress intensity region

Double torsion fracture analysis assumes linear elastic behaviour. For a perfectly linear elastic material, the relationship between K_{Ic} and crack length would appear as shown in Fig. 9 [34]. If the curve does not contain a horizontal section, which indicates a constant value of K_{Ic} over the corresponding region of crack growth, the results are not valid. This feature was used as a first step in determining the validity of fracture results for HDPE tested in double torsion.

Stress intensity versus crack length relationships were measured at 18, 0 and -20°C using a crosshead speed of 5 mm min⁻¹ (Figs 10–12). At 18°C there is no evidence of a constant K_{Ic} region. This indicates that at room temperature and moderate rates of loading the deviation from linear elastic behaviour is too great for valid results to be obtained.

As the temperature is lowered the plastic zone becomes smaller, and so the material response approximates more closely linear elastic behaviour. At 0 and -20°C a region of approximately constant K_{Ic} is observed. This suggests that the double torsion fracture results for HDPE may be valid at these lower temperatures.

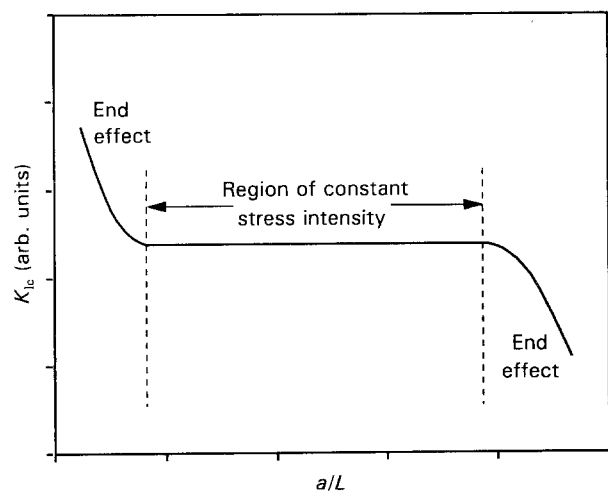

Figure 9 Diagram showing theoretical variation of K_{Ic} with crack length for a perfectly linear elastic double torsion fracture specimen (a is the length of the crack, L is the total length of the specimen).

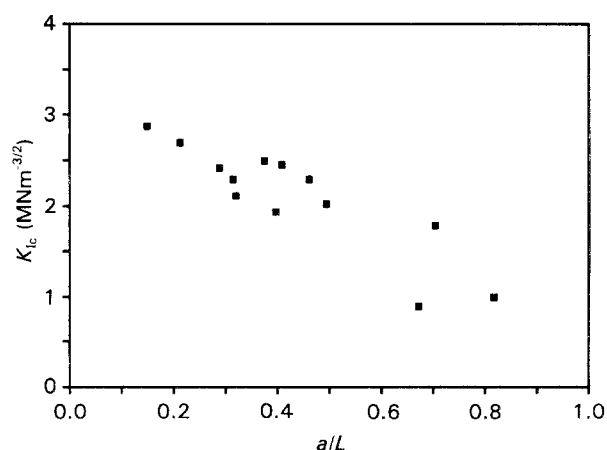

Figure 10 Critical stress intensity factor plotted as a function of crack length at 18°C. The crosshead speed was 5 mm min⁻¹.

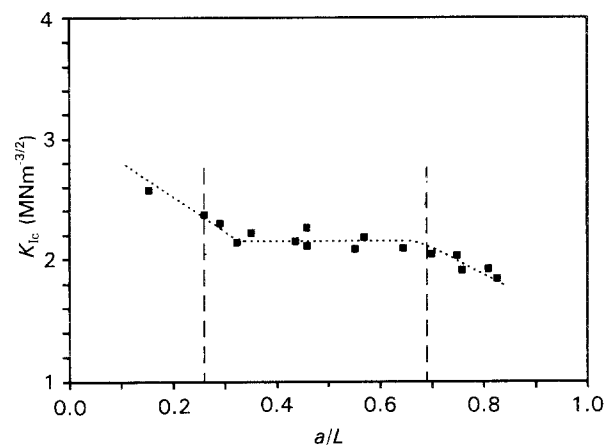

Figure 11 Critical stress intensity factor plotted as a function of crack length at 0°C. The crosshead speed was 5 mm min⁻¹.

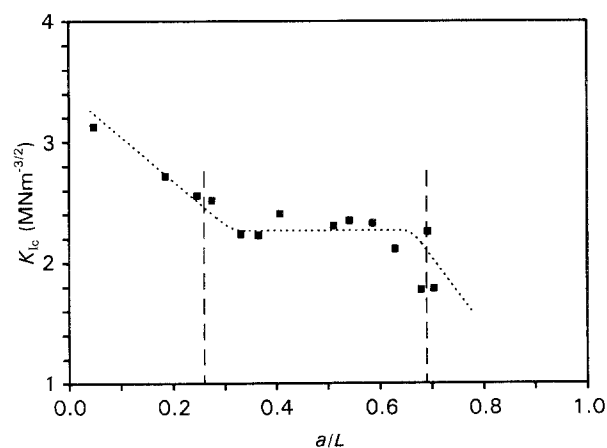

Figure 12 Critical stress intensity factor plotted as a function of crack length at -20°C. The crosshead speed was 5 mm min⁻¹.

Trantina [43] has used finite element analysis to determine the limiting crack lengths between which a constant stress intensity should be observed. The vertical dashed lines in Figs 11 and 12 represent these limits for a linear elastic sample of similar relative dimensions to the specimens used in this work. At

both 0 and -20°C there is good agreement between Trantina's limits and the observed region of constant K_{Ic} . This indicates that double torsion specimens of this grade of HDPE approximate linear elastic behaviour at 0°C and below.

3.2.2. Three-point bend tests

To check further the validity of the low-temperature double torsion results, the plateau values of K_{Ic} were compared to the fracture toughness measured in three-point bending. For this geometry the multi-specimen J -integral technique is well established [1, 5, 7, 44]. Specimens measuring 30 mm thick \times 30 mm broad \times 140 mm long were 60° chevron notched to half the depth of the specimen. A sharp notch was inserted at the root of the machined groove using a razor blade. Testing was conducted at a crosshead speed of 5 mm min^{-1} , and the span to breadth ratio was 4. The J -integral data are shown in Fig. 13. At 0°C the critical value was $J_{Ic} = 2.0\text{ kJ m}^{-2}$, whilst at -20°C a fracture toughness of 1.6 kJ m^{-2} was obtained.

The values of K_{Ic} obtained from the double torsion experiments are given in Table I. These were taken as an average over the region bounded by Trantina's limits. K_{Ic} is a stress-based fracture criterion, whereas J_{Ic} is an energy-based criterion. In order to compare results using the two geometries, it is necessary to

TABLE I Comparison of the fracture toughness values measured in double torsion with those measured in three-point bending

$T(^{\circ}\text{C})$	$K_{Ic}(\text{MN m}^{-3/2})$	$E(\text{MN m}^{-2})$	$G_{Ic}(\text{kJ m}^{-2})$	$J_{Ic}(\text{kJ m}^{-2})$
0	2.16 ± 0.05	2180 ± 170	1.8 ± 0.2	2.0 ± 0.1
-20	2.30 ± 0.09	2590 ± 150	1.7 ± 0.2	1.6 ± 0.1

convert K_{Ic} to an energy-based value such as G_{Ic} , the critical strain energy release rate. This is done using the equation [45]

$$G_{Ic} = \frac{K_{Ic}^2(1 - \nu^2)}{E} \quad (3)$$

where E is Young's modulus and ν is Poisson's ratio. The Young's modulus was determined in uniaxial tension. Values of ν were determined from the ratio of the Young's and shear moduli, and found to equal 0.4 at all test temperatures used. The converted fracture results are shown in Table I. Agreement between the double torsion data, G_{Ic} , and three-point bend data, J_{Ic} , is excellent at both 0 and -20°C .

In order to ascertain the validity of the double torsion results it is necessary to be sure that the measured fracture parameters were thickness independent. This requires that the fracture measurements are made under plain strain conditions. In three-point bending this requires that all specimen dimensions exceed $25(J_{Ic}/\sigma_y)$ [46]. For the samples used in this work, critical TPB dimensions of 1.5 mm and 1.1 mm were calculated at 0 and -20°C , respectively. The thickness of the specimens tested (15 mm) is well in excess of these limits. The values of J_{Ic} presented above can therefore be accepted as plane strain fracture results.

The ASTM thickness criterion for a plane-strain value of K_{Ic} is [47]

$$\text{all dimensions} \geq 2.5 \left(\frac{K_{Ic}}{\sigma_y} \right)^2 \quad (4)$$

The proportionality constant of 2.5 is purely empirical [47, 48]. It has been verified for various materials tested in a number of geometries, including HDPE in three-point bending [49]. However, the size requirements for double torsion tests have not yet been established [50]. Outwater et al. [18] have obtained valid double torsion results on an aluminium alloy at one-half the ASTM recommended thickness.

The stress intensities in Table I were measured on samples with a nominal thickness of 10 mm at the groove. The ASTM minimum thickness for these tests is 10.8 and 8.3 mm at 0 and -20°C , respectively. Although this criterion was not satisfied at 0°C , comparison with the J -integral data shows that valid results were still obtained. It is evident from this result that the ASTM minimum thickness requirement is conservative for HDPE in double torsion. It was not the purpose of this work to determine a more appropriate constant of proportionality for the plane strain criterion in double torsion. However, it can be stated with confidence that when the ASTM condition is satisfied the double torsion measurements will be made under plane strain.

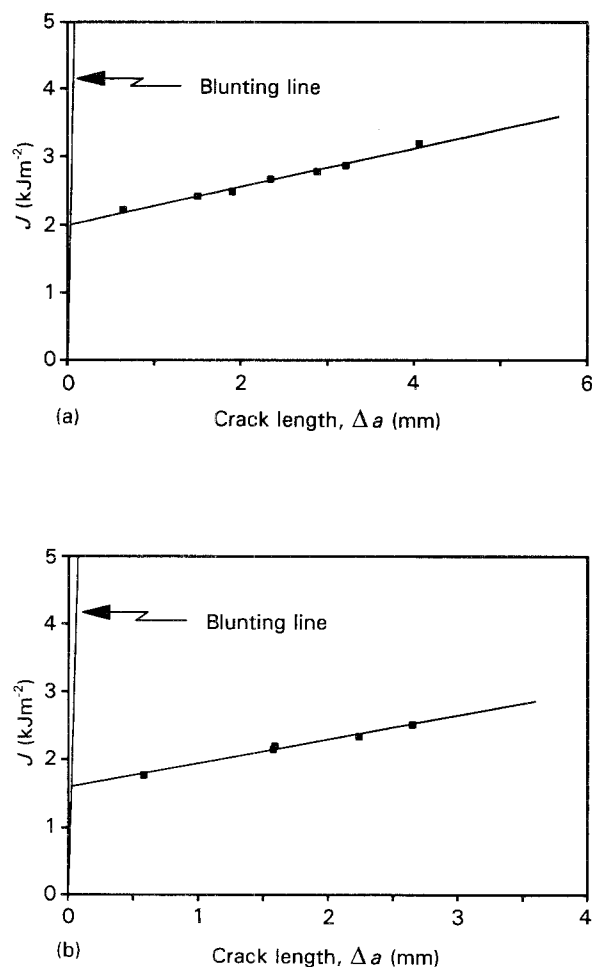

Figure 13 J -integral data at (a) 0°C and (b) -20°C .

4. Conclusion

This work has proved that valid fracture results can be obtained for high-density polyethylene at moderate loading rates using the double torsion geometry, provided the tests are performed at sub-ambient temperatures. For the grade of HDPE used in this work the maximum temperature at which valid fracture results were obtained was 0°C.

A simple method for electrical monitoring of the progress of the crack tip was described. This is particularly important for a material such as HDPE, because the crack initiates before the maximum load is applied. The ease of measuring crack speeds and the straightforward calculation of the fracture toughness makes double torsion tests well suited for measuring the relationship between the stress intensity factor and the speed of crack propagation.

Having demonstrated that valid fracture results can be obtained for high-density polyethylene in double torsion, the advantages of this geometry for studying crack growth in HDPE can be exploited with confidence. This work has now been completed, and will be presented in future publications.

Acknowledgement

The authors thank Dr David Barry for his assistance in developing the moulding technique.

References

1. M. K. V. CHAN and J. G. WILLIAMS, *Int. J. Fract.* **22** (1983) 145.
2. *Idem*, *Polymer* **24** (1983) 234.
3. X. LU, X. WANG and N. BROWN, *J. Mater. Sci.* **23** (1988) 643.
4. D. BARRY and O. DELATYCKI, *J. Polym. Sci. B Polym. Phys. Ed.* **25** (1987) 883.
5. I. NARISAWA, *Polym. Eng. Sci.* **27** (1987) 41.
6. X. LU and N. BROWN, *Polymer* **28** (1987) 1505.
7. D. B. BARRY and O. DELATYCKI, *J. Appl. Polym. Sci.* **38** (1989) 339.
8. N. BROWN and S. K. BHATTACHARYA, *J. Mater. Sci.* **20** (1985) 4553.
9. S. H. CARR, B. CRIST and T. J. MARKS, *Gov. Rep. Announce. Index* **85** (1985) 96.
10. K. TONYALI, C. ROGERS and H. R. BROWN, *J. Macromol. Sci. Phys.* **B28** (1989) 235.
11. N. BROWN, J. DONOFRIO and X. LU, *Polymer* **28** (1987) 1326.
12. M. FLEIBNER, *Kunststoffe* **77** (1987) 1.
13. D. J. GERRY, PhD thesis, University of Vermont (1966).
14. J. A. KIES and B. J. CLARK, in "Proceedings of the 2nd International Conference on Fracture", Brighton, April 1969, edited by P. L. Pratt (Chapman and Hall, London, 1969) p. 483.
15. J.-C. POLLET and S. J. BURNS, "Evaluation for ASTM E-24.07.02" (American Society for Testing and Materials, Philadelphia, PA, 1979).
16. F. P. CHAMPOMIER, in "Fracture Mechanics Applied to Brittle Materials", ASTM STP 678, edited by S. W. Freiman (American Society for Testing and Materials, Philadelphia, PA, 1979) p. 60.
17. T. A. MICHALSKE, M. SINGH and V. D. FRECHETTE, in "Fracture Mechanics Methods for Ceramics, Rocks, and Concrete", ASTM STP 745, edited by S. W. Freiman and E. R. Fuller (American Society for Testing and Materials, Philadelphia, PA, 1981) p. 3.
18. J. O. OUTWATER, M. C. MURPHY, R. G. KUMBLE and J. T. BERRY, in "Fracture Toughness and Slow-Stable Cracking", ASTM STP 559 (American Society for Testing and Materials, Philadelphia, PA, 1974) p. 127.
19. A. G. EVANS, M. LINZER and L. R. RUSSELL, *Mater. Sci. Eng.* **15** (1974) 253.
20. D. P. WILLIAMS and A. G. EVANS, *J. Test. Eval.* **1** (1973) 264.
21. A. G. EVANS, *J. Mater. Sci.* **7** (1972) 1137.
22. M. MATSUI, T. SOMA and I. ODA, in "Fracture Mechanics of Ceramics", Vol. 4, edited by D. Bradt, P. H. Hasselman and F. F. Lange (Plenum Press, New York, 1978) p. 711.
23. J. G. BRUCE, W. W. GERBERICH and B. G. KOEPKE, *ibid.*, p. 687.
24. C. G. ANNIS and J. S. CARGILL, *ibid.*, p. 737.
25. T. FETT, K. KELLER and D. MUNZ, *Int. J. Fract.* **36** (1988) 3.
26. R. J. YOUNG and P. W. R. BEAUMONT, *J. Mater. Sci.* **10** (1975) 1343.
27. P. S. LEEVERS, *ibid.* **17** (1982) 2469.
28. W. J. CANTWELL, A. C. ROULIN-MOLONEY and H. H. KAUSCH, *J. Mater. Sci. Lett.* **7** (1988) 976.
29. R. J. YOUNG and P. W. R. BEAUMONT, *J. Mater. Sci.* **12** (1977) 684.
30. B. STALDER and H. H. KAUSCH, *ibid.* **17** (1982) 2481.
31. G. P. MARSHALL, L. H. COUTTS and J. G. WILLIAMS, *ibid.* **9** (1974) 1409.
32. R. FRASSINE, T. RICCÒ, M. RINK and A. PAVAN, *ibid.* **23** (1988) 4027.
33. P. W. R. BEAUMONT and R. J. YOUNG, *ibid.* **10** (1975) 1334.
34. B. J. PLETKA, E. R. FULLER and B. G. KOEPKE, in "Fracture Mechanics Applied to Brittle Materials", ASTM STP 678, edited by S. W. Freiman (American Society for Testing and Materials, Philadelphia, PA, 1979) p. 19.
35. P. J. HINE, R. A. DUCKETT and I. M. WARD, *J. Mater. Sci.* **19** (1984) 3796.
36. P. S. LEEVERS and J. G. WILLIAMS, *ibid.* **22** (1987) 1097.
37. B. J. PLETKA and S. M. WIEDERHORN, in "Fracture Mechanics of Ceramics" edited by R. G. Bradt, D. P. H. Hasselman and F. F. Lange (Plenum Press, New York, 1977) p. 745.
38. F. E. BAILEY and R. WALTER, *Polym. Eng. Sci.* **15** (1975) 842.
39. Y. CHAOTING, N. H. LADIZESKY and I. M. WARD, *J. Macromol. Sci. Phys.* **B27** (1988) 41.
40. P. S. LEEVERS, *J. Mater. Sci. Lett.* **5** (1986) 191.
41. S. R. ANTHONY, J. P. CHUBB and J. CONGLETON, *Philos. Mag.* **22** (1970) 1201.
42. A. M. SERRANO, G. E. WELSCH and R. GIBALA, *Polym. Eng. Sci.* **22** (1982) 934.
43. G. G. TRANTINA, *J. Am. Ceram. Soc.* **60** (1977) 388.
44. S. HASHEMI and J. G. WILLIAMS, *Polym. Eng. Sci.* **26** (1986) 760.
45. J. G. WILLIAMS, "Fracture Mechanics of Polymers" (Ellis Horwood, Chichester, 1984).
46. ASTM E813-81, "Standard Test Method for J_{Ic} : A Measure of Fracture Toughness" (American Society for Testing and Materials, Philadelphia, PA).
47. ASTM E399-83, "Standard Test Method for Plane Strain Fracture Toughness of Metallic Materials", (American Society for Testing and Materials, Philadelphia, PA).
48. J. E. SRAWLEY, M. H. JONES and W. F. BROWN, *Mater. Res. Stand.* **7** (1967) 262.
49. M. K. V. CHAN and J. G. WILLIAMS, *Polym. Eng. Sci.* **21** (1981) 1019.
50. T. RICCÒ, R. FRASSINE and A. PAVAN, *J. Mater. Sci.* **25** (1990) 1517.

Received 28 January 1993
and accepted 16 May 1994